

DIN rail mounting frame - HC-CIF-B16-BFWD-FH-AL - 1404217

Please be informed that the data shown in this PDF Document is generated from our Online Catalog. Please find the complete data in the user's documentation. Our General Terms of Use for Downloads are valid (<http://phoenixcontact.com/download>)



HEAVYCON DIN rail mounting frame, lower part with double locking latch, for sleeve housing without double locking latch or HC-CIF-..HFFD.. upper part, for type B16 contact inserts, for NS35/7,5 DIN rails

Your advantages

- ✓ Sturdy metal version
- ✓ Open base, pre-assembled cable harnesses can be used
- ✓ Standardized design; both PE sheets for inserts are connected conductively
- ✓ Safe capacitive PE even when connected slightly askew



Key Commercial Data

Packing unit	1 pc
GTIN	 4 046356 681896
GTIN	4046356681896

Technical data

Dimensions

Length	93.5 mm
Width	56 mm
Height	85 mm

Ambient conditions

Ambient temperature (operation)	-40 °C ... 125 °C
---------------------------------	-------------------

General

Size	For B16
Material	Cast aluminum, uncoated
Locking latch material	High-grade steel, handle: PA-GF
Assembly instructions	A double locking latch is not mounted, which means that an assembled cable set can be used more easily

DIN rail mounting frame - HC-CIF-B16-BFWD-FH-AL - 1404217

Technical data

General

Mounting type	DIN rail: 35 mm
---------------	-----------------

Environmental Product Compliance

China RoHS	Environmentally friendly use period: unlimited = EFUP-e
	No hazardous substances above threshold values

Drawings

Dimensional drawing

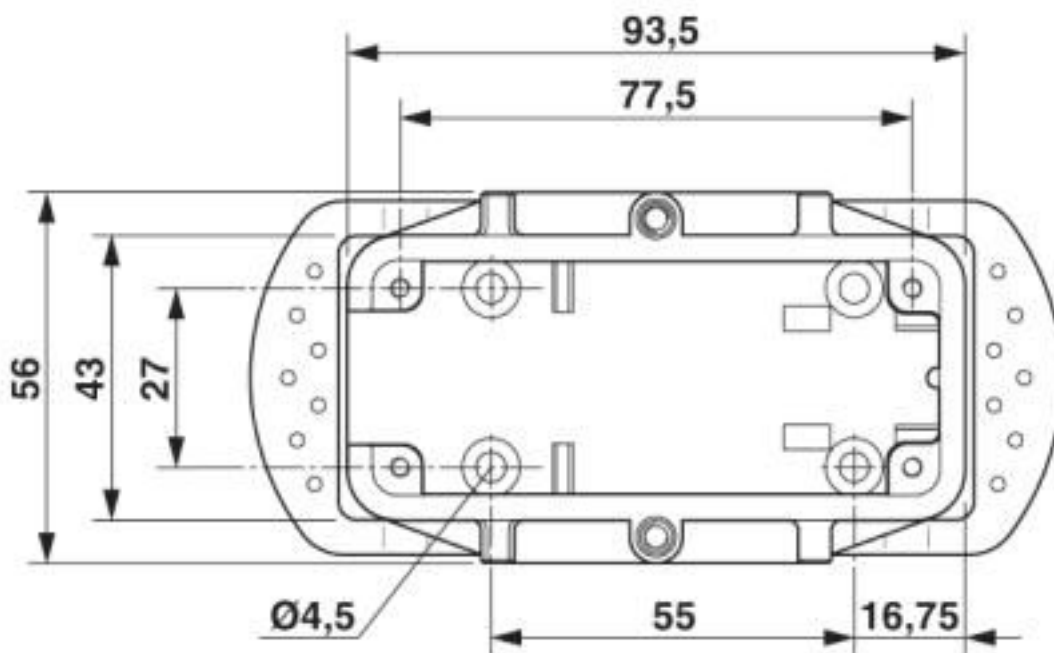

Dimensional drawing top view

DIN rail mounting frame - HC-CIF-B16-BFWD-FH-AL - 1404217

Dimensional drawing

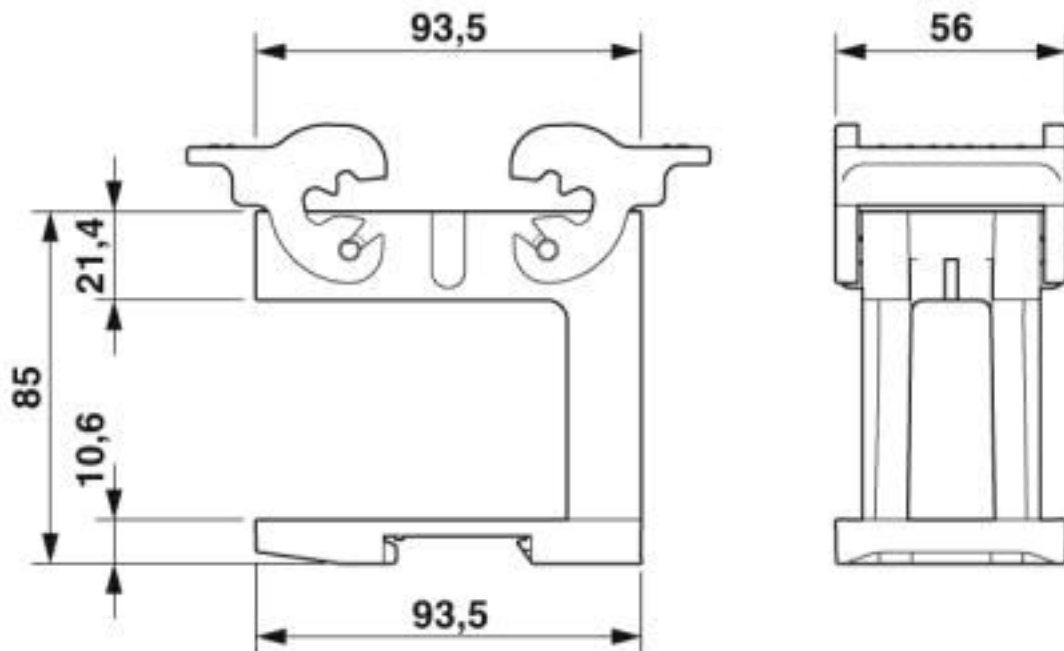

Dimensional drawing

Classifications

eCl@ss

eCl@ss 10.0.1	27440210
eCl@ss 11.0	27440210
eCl@ss 4.0	27140800
eCl@ss 4.1	27140800
eCl@ss 5.0	27143400
eCl@ss 5.1	27143400
eCl@ss 6.0	27261200
eCl@ss 7.0	27440206
eCl@ss 8.0	27440206
eCl@ss 9.0	27440210

ETIM

ETIM 3.0	EC002310
ETIM 4.0	EC002310
ETIM 5.0	EC002310
ETIM 6.0	EC002310
ETIM 7.0	EC002310

UNSPSC

UNSPSC 6.01	43172601
-------------	----------

DIN rail mounting frame - HC-CIF-B16-BFWD-FH-AL - 1404217

Classifications

UNSPSC

UNSPSC 7.0901	39121416
UNSPSC 11	43172601
UNSPSC 12.01	39121408
UNSPSC 13.2	39121421
UNSPSC 18.0	39121421
UNSPSC 19.0	39121421
UNSPSC 20.0	39121421
UNSPSC 21.0	39121421

Approvals

Approvals

Approvals

EAC

Ex Approvals

Approval details

EAC		RU C- DE.AI30.B.01102
-----	--	--------------------------

Accessories

Additional products

DIN rail mounting frame - HC-CIF-B16-HFFD-WH-AL - 1404218



HEAVYCON DIN rail mounting frame, upper part for double locking latch, for HC-CIF...BFWD.. lower parts with double locking latch or for HC-CIF...BFFD.. lower parts, for type B16 contact inserts, with M4 screws with 3 mm Allen screw head, for NS35/7,5 DIN rails

Phoenix Contact 2020 © - all rights reserved
<http://www.phoenixcontact.com>

PHOENIX CONTACT GmbH & Co. KG
Flachmarktstr. 8
32825 Blomberg
Germany
Tel. +49 5235 300
Fax +49 5235 3 41200
<http://www.phoenixcontact.com>