

Counter nut - A-INL-M20-P-LG - 1414570

Please be informed that the data shown in this PDF Document is generated from our Online Catalog. Please find the complete data in the user's documentation. Our General Terms of Use for Downloads are valid (<http://phoenixcontact.com/download>)

Counter nut, material: PA 6 GF 30, for threads M20 x 1.5, color: lightgrey RAL 7035



Key Commercial Data

Packing unit	5 pc
GTIN	 4 055626 029214
GTIN	4055626029214

Technical data

Dimensions

Length	6 mm
Connecting thread diameter	20 mm
Wrench size, counter nut	26 mm
Hexagon angular dimension	28.6 mm

Ambient conditions

Ambient temperature (operation)	-40 °C ... 100 °C
---------------------------------	-------------------

General

Material	PA 6 GF 30
Thread type on connection side	M20 x 1.5
Color	lightgrey RAL 7035

Standards and Regulations

Halogen-free	yes
--------------	-----

Environmental Product Compliance

China RoHS	Environmentally friendly use period: unlimited = EFUP-e
	No hazardous substances above threshold values

Counter nut - A-INL-M20-P-LG - 1414570

Drawings

Dimensional drawing

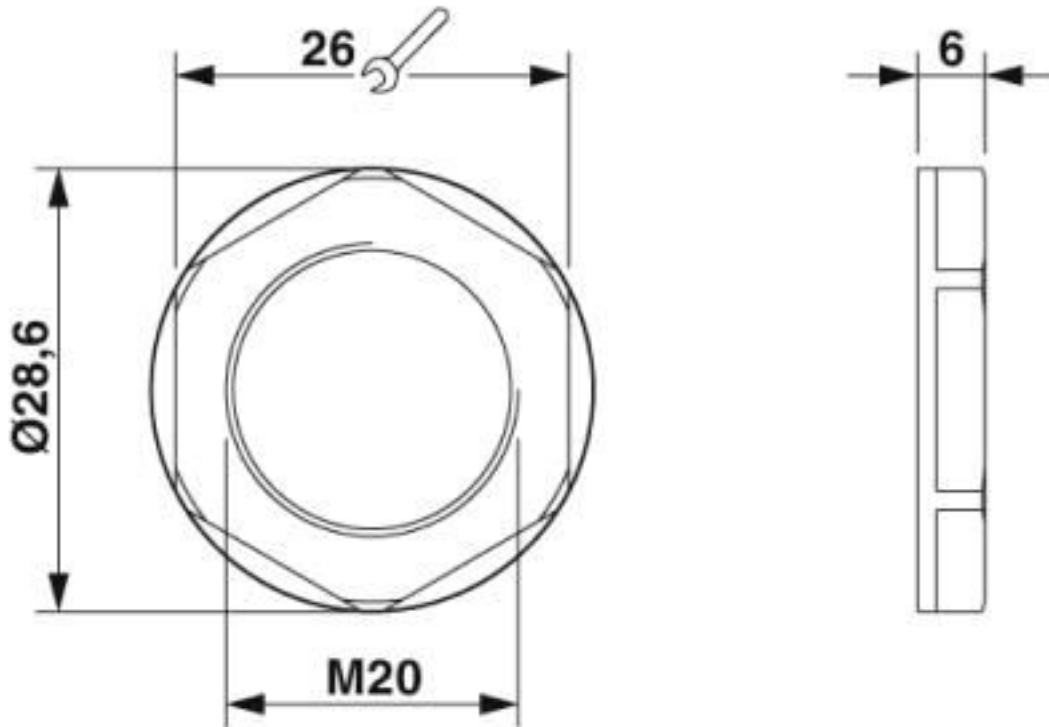

Classifications

eCl@ss

eCl@ss 10.0.1	27144424
eCl@ss 11.0	27144424
eCl@ss 4.0	23110700
eCl@ss 4.1	23110700
eCl@ss 5.0	23110700
eCl@ss 5.1	23110700
eCl@ss 6.0	23110700
eCl@ss 7.0	23110701
eCl@ss 8.0	27069219
eCl@ss 9.0	27144424

ETIM

ETIM 5.0	EC000129
ETIM 6.0	EC000940
ETIM 7.0	EC000940

Counter nut - A-INL-M20-P-LG - 1414570

Classifications

UNSPSC

UNSPSC 13.2	31161727
UNSPSC 18.0	31161716
UNSPSC 19.0	31161716
UNSPSC 20.0	31161716
UNSPSC 21.0	31161716

Phoenix Contact 2020 © - all rights reserved
<http://www.phoenixcontact.com>

PHOENIX CONTACT GmbH & Co. KG
Flachsmarktstr. 8
32825 Blomberg
Germany
Tel. +49 5235 300
Fax +49 5235 3 41200
<http://www.phoenixcontact.com>