



AAV6593001

Altivar

VW3 A9 629 ... 641, VW3 A9 644 ... 649

VW3 A9 629 - 630

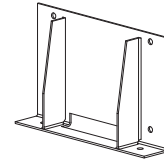
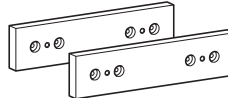
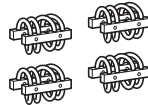

VW3 A9 631 - 632

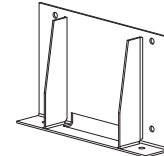
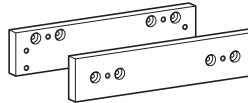
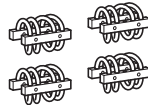

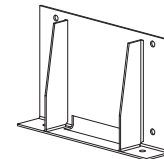
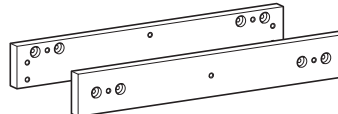
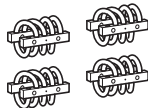

VW3 A9 633 ... 638, VW3 A9 644 ... 647

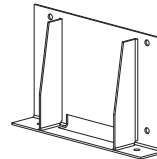
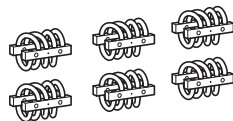
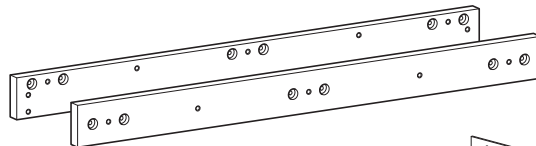

VW3 A9 639 ... 641, VW3 A9 648, VW3 A9 649



	ATV71	ATV61
VW3 A9 629	HD55M3XD, HD90N4D	HD55M3XD, HD75M3XD, HD90N4D
VW3 A9 630	-	HC11N4D
VW3 A9 631	HD75M3XD, HC11N4D	HD90M3XD
VW3 A9 632	-	HC13N4D
VW3 A9 633	HC13N4D	-
VW3 A9 634	-	HC16N4D
VW3 A9 635	HC16N4D	HC22N4D  200 kW
VW3 A9 636	-	HC22N4D  220 kW
VW3 A9 637	HC20N4D	HC25N4D
VW3 A9 638	HC25N4D, HC28N4D	HC31N4D
VW3 A9 639	HC31N4D	HC40N4D
VW3 A9 640	HC40N4D	HC50N4D
VW3 A9 641	HC50N4D	HC63N4D
VW3 A9 644	HC11Y	HC11Y, HC13Y
VW3 A9 645	HC13Y, HC16Y	HC16Y, HC20Y
VW3 A9 646	HC20Y	HC25Y
VW3 A9 647	HC25Y, HC31Y	HC31Y, HC40Y
VW3 A9 648	HC40Y	HC50Y
VW3 A9 649	HC50Y, HC63Y	HC63Y, HC80Y

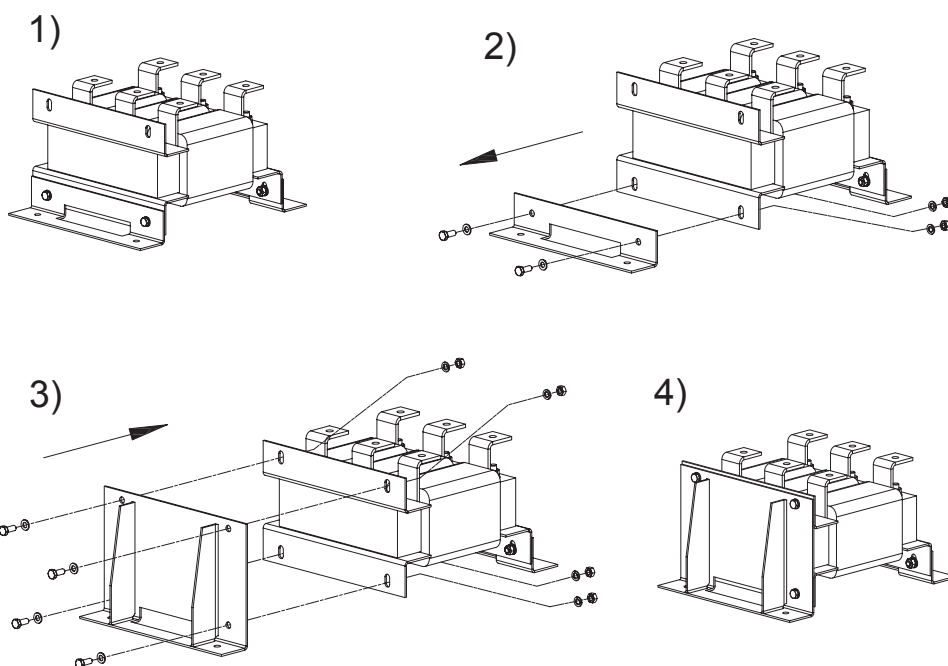

VW3 A9 629 - 630

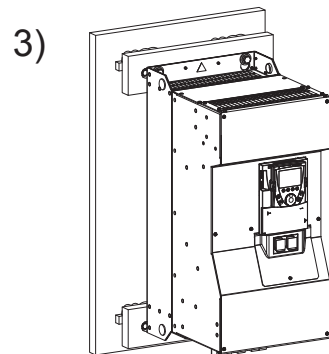
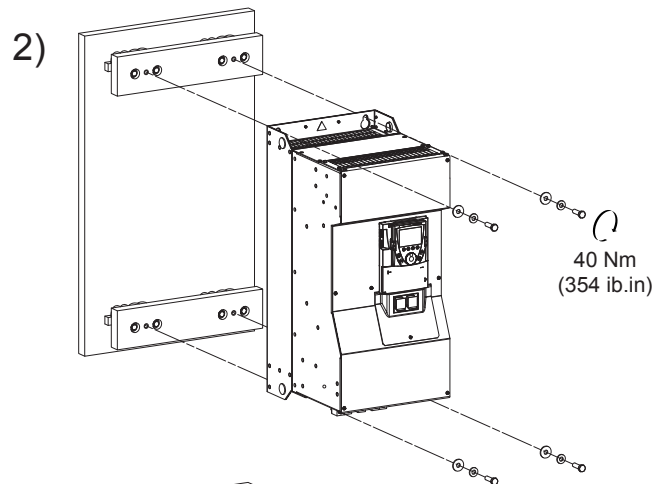
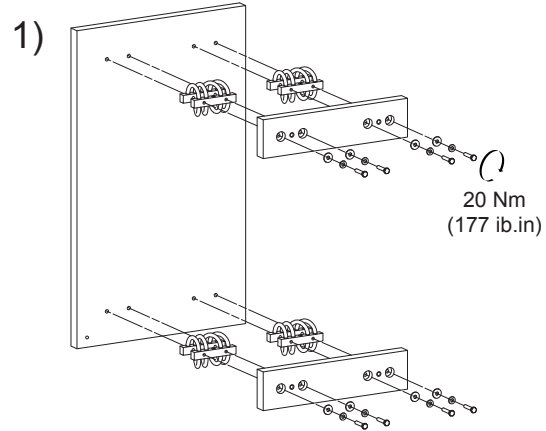

VW3 A9 631 - 632

1)

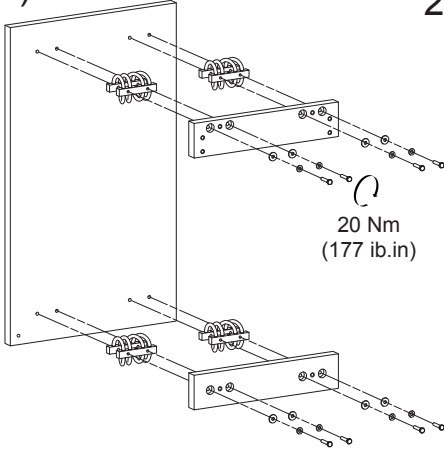

2)

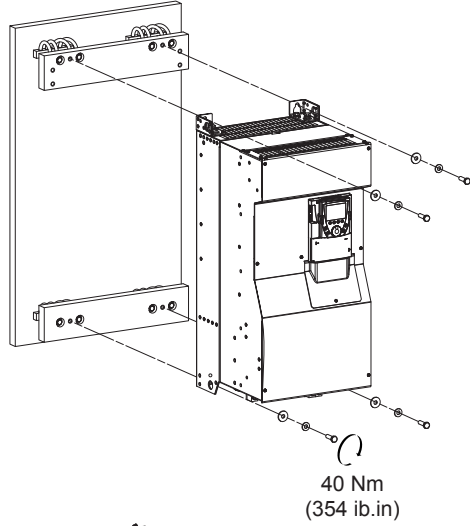

3)

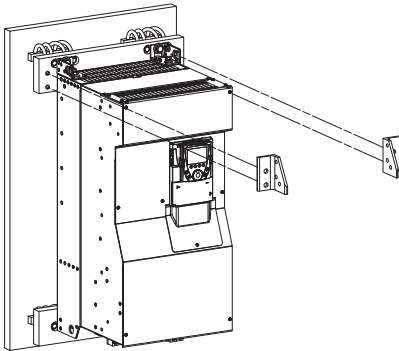

4)

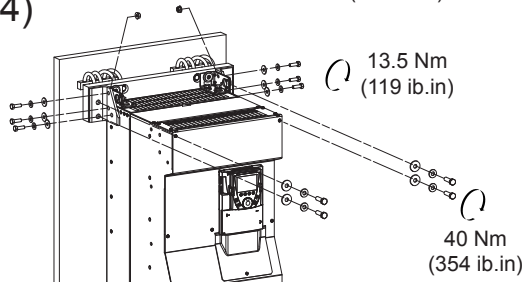

5)

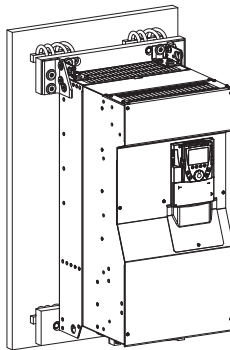

VW3 A9 633 ... 638
VW3 A9 644 ... 647

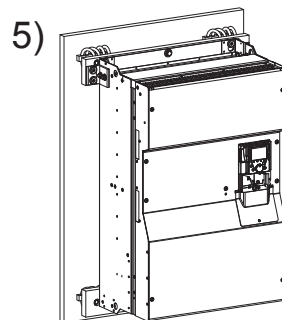
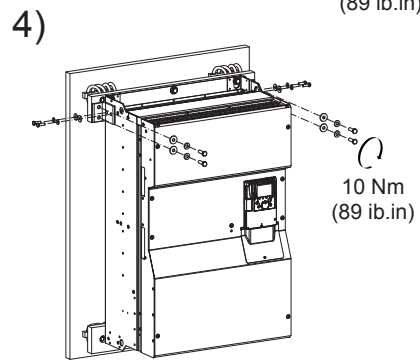
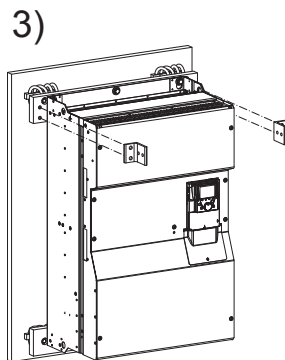
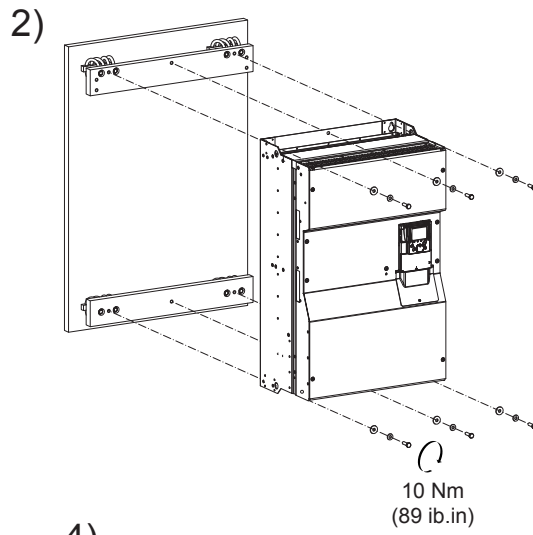
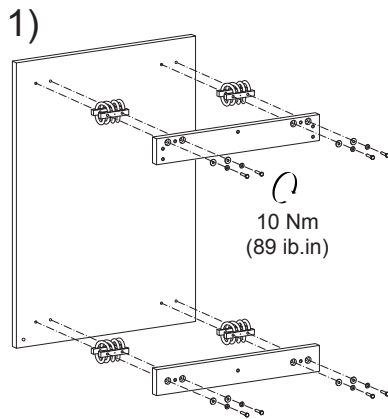

VW3 A9 639, 640, 641
VW3 A9 648, 649

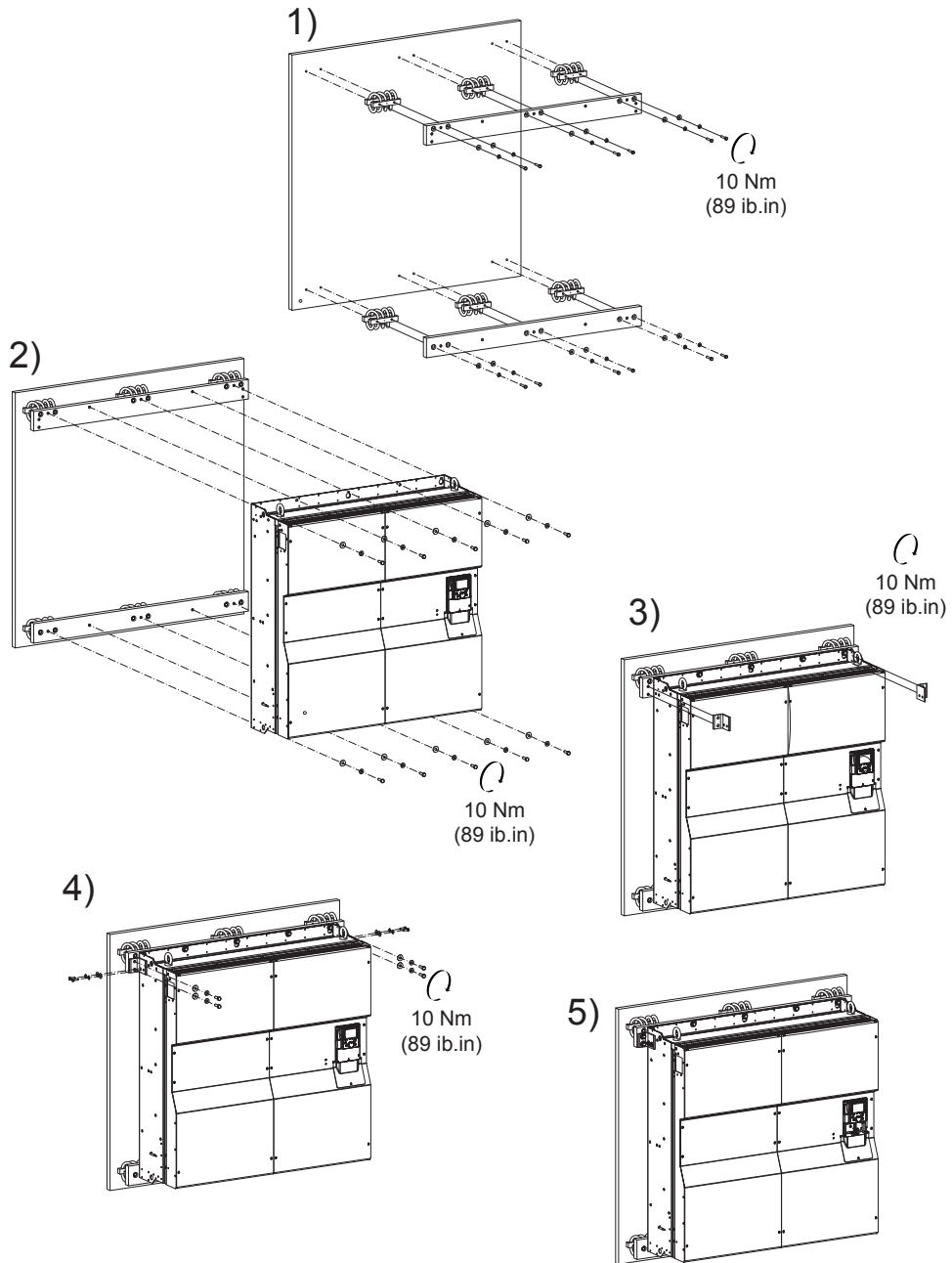

VW3 A9 629 ... 638, VW3 A9 644 ... 647

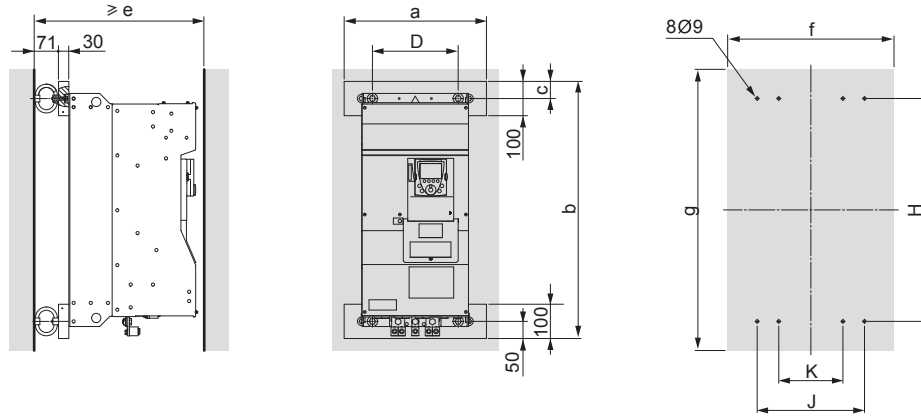

VW3 A9 639 ... 641, VW3 A9 648, VW3 A9 649

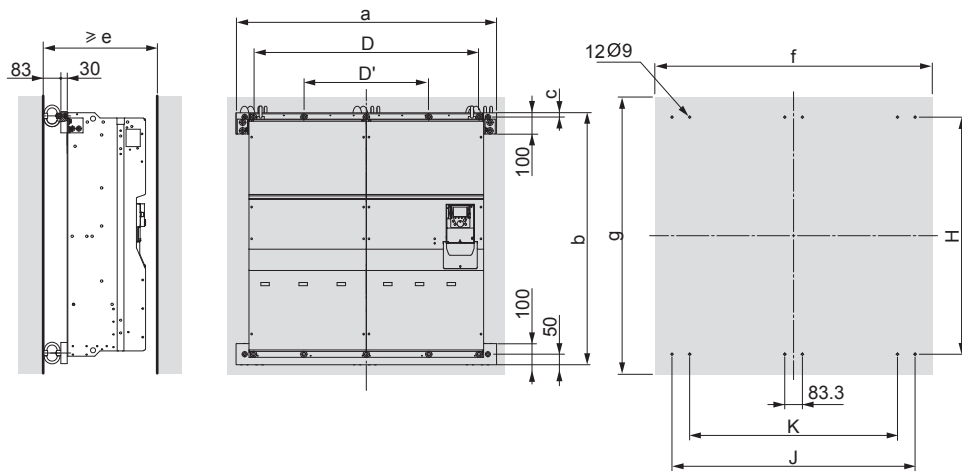

VW3 A9	a mm (in)	b mm (in)	c mm (in)	D mm (in)	D' mm (in)	e mm (in)	f mm (in)	g mm (in)	H mm (in)	J mm (in)	K mm (in)
629, 630	415 (16.35)	750 (29.55)	50 (1.97)	250 (9.85)	-	530 (20.88)	485 (19.11)	820 (32.31)	650 (25.61)	313 (12.33)	187 (7.37)
631, 632	465 (18.32)	828 (32.62)	20 (0.79)	298 (11.74)	-	530 (20.88)	535 (21.08)	920 (36.25)	758 (29.87)	361 (14.22)	235 (9.26)
633, 634, 644, 645	450 (17.73)	990 (39.01)	20 (0.79)	285 (11.23)	-	530 (20.88)	520 (20.49)	1100 (43.34)	920 (36.25)	348 (13.71)	222 (8.75)
635, 636	550 (21.67)	990 (39.01)	20 (0.79)	350 (13.79)	-	530 (20.88)	620 (24.43)	1100 (43.34)	920 (36.25)	413 (16.27)	287 (11.31)
637, 638, 646, 647	700 (27.58)	990 (39.01)	20 (0.79)	540 (21.28)	-	530 (20.88)	770 (30.34)	1100 (43.34)	920 (36.25)	603 (23.76)	477 (18.79)
639, 640	1000 (39.40)	1190 (46.89)	20 (0.79)	835 (32.90)	420 (16.55)	545 (21.47)	1080 (42.55)	1310 (51.61)	1120 (44.13)	918.3 (36.17)	751.7 (29.62)
641, 648, 649	1230 (48.46)	1190 (46.89)	20 (0.79)	1065 (41.96)	590 (23.25)	545 (21.47)	1310 (51.61)	1310 (51.61)	1120 (44.13)	1148.3 (45.24)	981.7 (38.68)

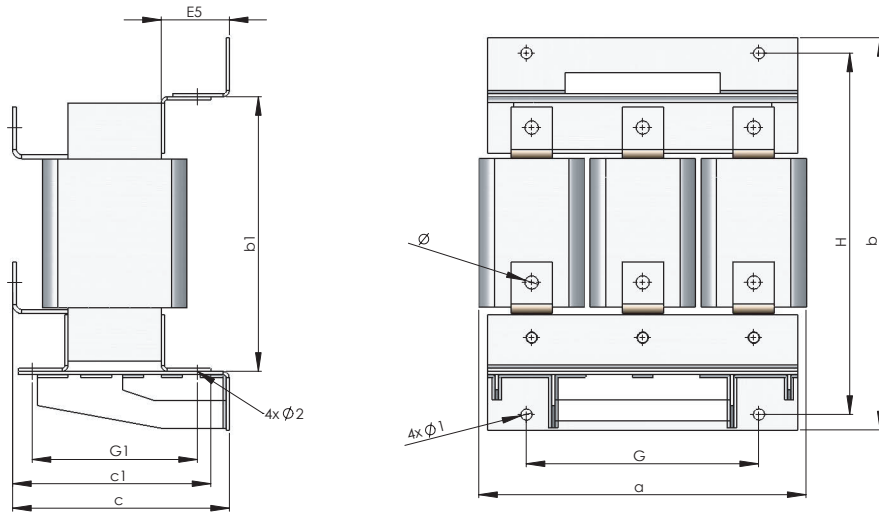

VW3 A4	a mm (in)	b mm (in)	b1 mm (in)	c mm (in)	c1 mm (in)	G mm (in)	G1 mm (in)	H mm (in)	Ø mm (in)	Ø1 mm (in)	Ø2 mm (in)	E5 mm (in)
560	320 (12.61)	380 (14.97)	270 (10.64)	210 (8.27)	200 (7.88)	225 (8.87)	150 (5.91)	350 (13.79)	13 (0.51)	11 (0.43)	11 (0.43)	56 (2.21)
568	320 (12.61)	380 (14.97)	270 (10.64)	210 (8.27)	200 (7.88)	225 (8.87)	140 (5.52)	350 (13.79)	11 (0.43)	11 (0.43)	11 (0.43)	56 (2.21)
570	275 (10.83)	305 (12.02)	240 (9.46)	210 (8.27)	200 (7.88)	200 (7.88)	125 (4.92)	275 (10.83)	9 (0.35)	9 (0.35)	9 (0.35)	52 (2.05)
571	385 (15.17)	430 (16.94)	310 (12.21)	265 (10.44)	245 (9.65)	300 (11.82)	150 (5.91)	400 (15.76)	13 (0.51)	13 (0.51)	13 (0.51)	63 (2.48)
572	385 (15.17)	430 (16.94)	310 (12.21)	305 (12.02)	295 (11.62)	300 (11.82)	190 (7.49)	400 (15.76)	13 (0.51)	13.5 (0.53)	13.5 (0.53)	63 (2.48)