

Housing - HC-B 48-AML - 1772175

Please be informed that the data shown in this PDF Document is generated from our Online Catalog. Please find the complete data in the user's documentation. Our General Terms of Use for Downloads are valid (<http://phoenixcontact.com/download>)



HEAVYCON panel mounting base B48, with single locking latch, height 41 mm, with flat gasket



Key Commercial Data

Packing unit	1 pc
GTIN	 4 017918 036843
GTIN	4017918036843

Technical data

Dimensions

Height	41 mm
Width	112 mm
Length	165 mm
Length of the assembly cutout	82 mm
Width of the assembly cutout	120 mm

Ambient conditions

Degree of protection (IP)	IP65 (When plugged in)
Ambient temperature (operation)	-40 °C ... 125 °C

General

Note	For contact inserts HC-B48, DD216, M
Size	B48
Housing type	Panel mounting base
Color	gray
Locking type	with single locking latch
Screw connection	none
Housing material	Aluminum die-cast

Housing - HC-B 48-AML - 1772175

Technical data

General

Housing surface material	Powder-coated, gray
Seal material	NBR
Material lock	Steel, galvanized

Environmental Product Compliance

China RoHS	Environmentally friendly use period: unlimited = EFUP-e
	No hazardous substances above threshold values

Drawings

Dimensional drawing

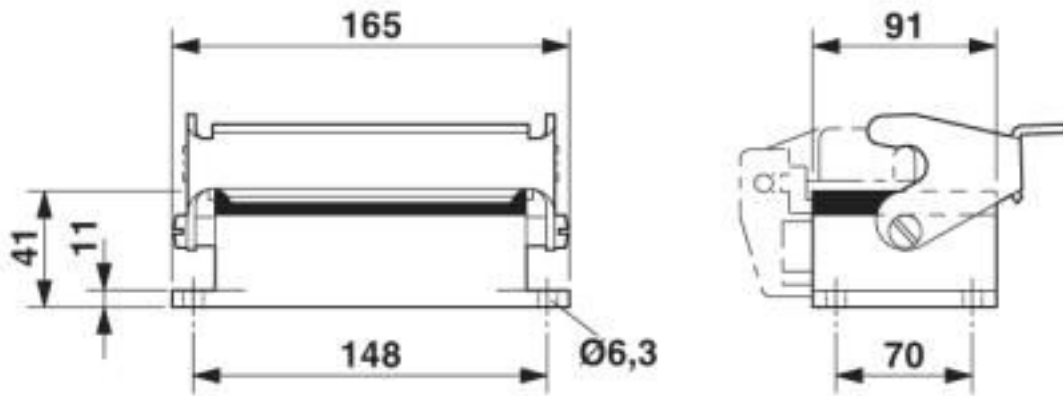

Dimensional drawing

Housing - HC-B 48-AML - 1772175

Dimensional drawing

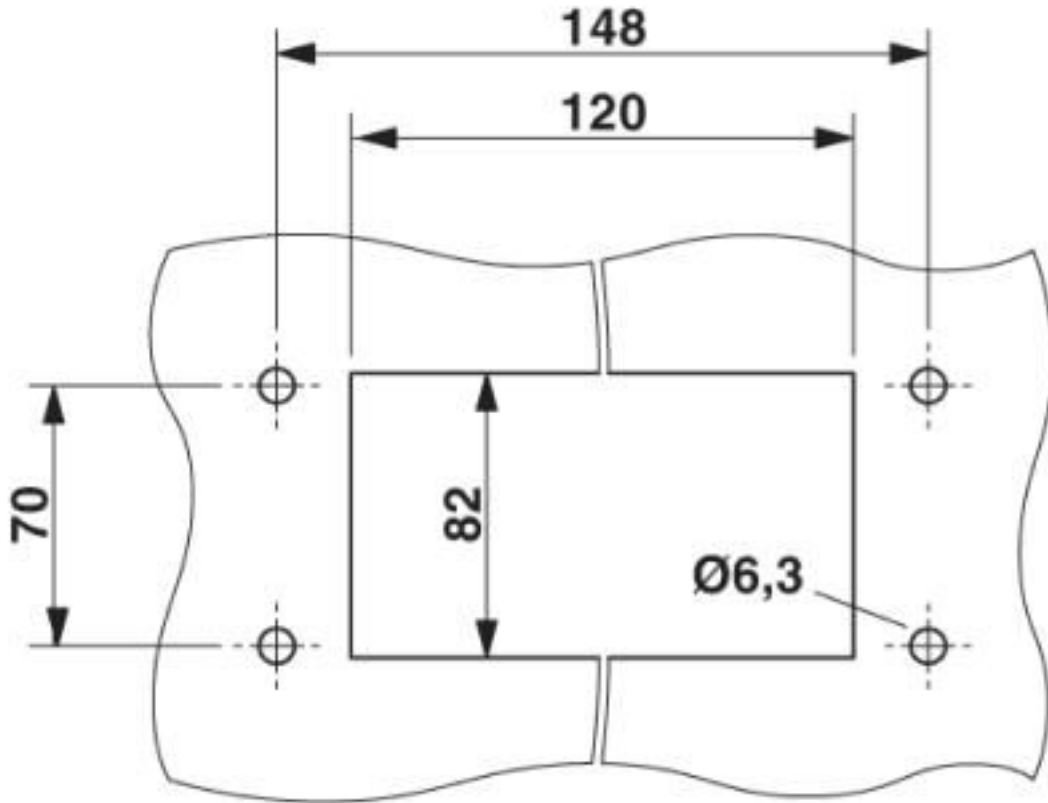

Mounting cutout

Classifications

eCl@ss

eCl@ss 10.0.1	27440202
eCl@ss 11.0	27440202
eCl@ss 4.0	27140800
eCl@ss 4.1	27140800
eCl@ss 5.0	27143400
eCl@ss 5.1	27261200
eCl@ss 6.0	27261200
eCl@ss 7.0	27440202
eCl@ss 8.0	27440202
eCl@ss 9.0	27440202

ETIM

ETIM 2.0	EC000437
ETIM 3.0	EC000437
ETIM 4.0	EC000437

Housing - HC-B 48-AML - 1772175

Classifications

ETIM

ETIM 5.0	EC000437
ETIM 6.0	EC000437
ETIM 7.0	EC000437

UNSPSC

UNSPSC 6.01	31261502
UNSPSC 7.0901	31261502
UNSPSC 11	31261502
UNSPSC 12.01	31261502
UNSPSC 13.2	31261501
UNSPSC 18.0	31261501
UNSPSC 19.0	31261501
UNSPSC 20.0	31261501
UNSPSC 21.0	31261501

Approvals

Approvals

Approvals

EAC

Ex Approvals

Approval details

EAC		RU C- DE.AI30.B.01102
-----	---	--------------------------

Phoenix Contact 2020 © - all rights reserved
<http://www.phoenixcontact.com>

PHOENIX CONTACT GmbH & Co. KG
Flachsmarktstr. 8
32825 Blomberg
Germany
Tel. +49 5235 300
Fax +49 5235 3 41200
<http://www.phoenixcontact.com>