

Housing - HC-B 6-SML-52/M1M20 - 1586730

Please be informed that the data shown in this PDF Document is generated from our Online Catalog. Please find the complete data in the user's documentation. Our General Terms of Use for Downloads are valid (<http://phoenixcontact.com/download>)



Box mounting base, with single locking latch, height 52 mm, with screw connection, 1x M20



Key Commercial Data

Packing unit	10 pc
GTIN	
GTIN	4046356426824

Technical data

Dimensions

Height	52 mm
Width	52 mm
Length	84 mm
Wrench size, union nut	20 mm
External cable diameter	5 mm ... 12 mm

Ambient conditions

Degree of protection of housing (IP)	IP65
Ambient temperature (operation)	-40 °C ... 125 °C

General

Size	B6
Housing type	Box mounting bases
Locking type	with single locking latch
No. of cable outlets	1
Cable outlet	left (view of the opened single locking latch)
Screw connection	with
Type of the screw connection	1x M20

Housing - HC-B 6-SML-52/M1M20 - 1586730

Technical data

General

Housing material	Aluminum die-cast
Housing surface material	Powder-coated, gray
Seal material	NBR
Cable gland material	Nickel-plated brass
Cable seal material	NBR
Material lock	Stainless steel, handle: PA
Material grip body interlock	PA

Environmental Product Compliance

China RoHS	Environmentally friendly use period: unlimited = EFUP-e
	No hazardous substances above threshold values

Drawings

Dimensional drawing

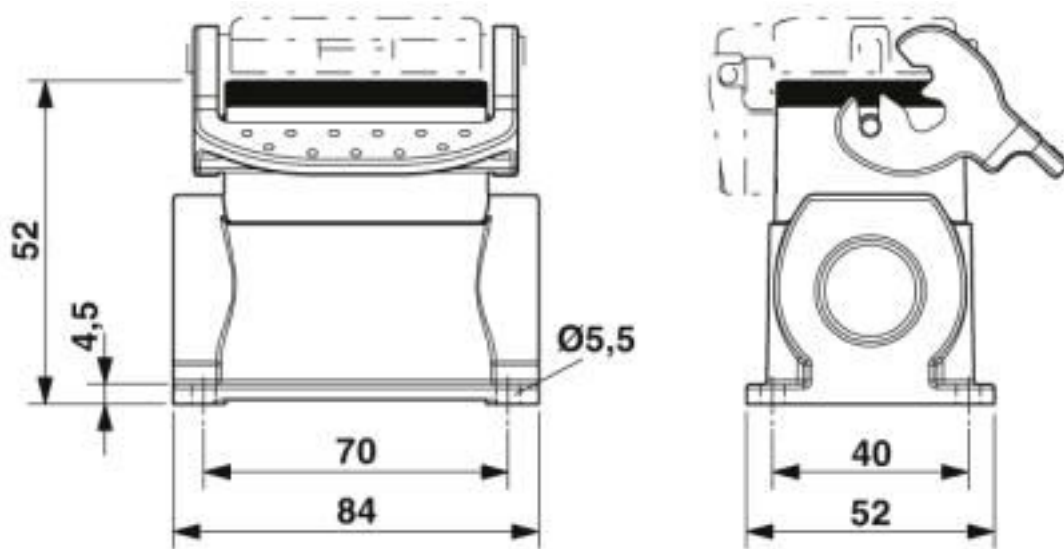

Dimensional drawing

Classifications

eCl@ss

eCl@ss 10.0.1	27440202
eCl@ss 11.0	27440202
eCl@ss 4.0	27140800
eCl@ss 4.1	27140800
eCl@ss 5.0	27143400
eCl@ss 5.1	27261200
eCl@ss 6.0	27261200

Housing - HC-B 6-SML-52/M1M20 - 1586730

Classifications

eCl@ss

eCl@ss 7.0	27440202
eCl@ss 8.0	27440202
eCl@ss 9.0	27440202

ETIM

ETIM 3.0	EC000437
ETIM 4.0	EC000437
ETIM 5.0	EC000437
ETIM 6.0	EC000437
ETIM 7.0	EC000437

UNSPSC

UNSPSC 6.01	31261502
UNSPSC 7.0901	31261502
UNSPSC 11	31261502
UNSPSC 12.01	31261502
UNSPSC 13.2	31261501
UNSPSC 18.0	31261501
UNSPSC 19.0	31261501
UNSPSC 20.0	31261501
UNSPSC 21.0	31261501

Approvals

Approvals

Approvals

EAC

Ex Approvals

Approval details

EAC		RU C- DE.AI30.B.01102
-----	--	--------------------------

Accessories

Accessories

Full screw connection

Housing - HC-B 6-SML-52/M1M20 - 1586730

Accessories

Cable gland - G-INS-M20-S68N-NNES-S - 1411163



Cable gland, cable gland material: Nickel-plated brass, external cable diameter 6 mm ... 12 mm, shielding: no, connecting thread: M20 x 1.5, color: silver, with O-ring

Cable gland - HC-M-KV-M20(11-16) - 1645998



Metal screw connection up to 5 bar, thread length: 6 mm, cable diameter: 11 - 16 mm, WAF 27, screw connection: M20

Cable gland - HC-M-KV-M20(1ASI) - 1584017



Metal screw connection for an AS-Interface flat-ribbon conductor, thread type M20

Phoenix Contact 2020 © - all rights reserved
<http://www.phoenixcontact.com>

PHOENIX CONTACT GmbH & Co. KG
Flachsmarktstr. 8
32825 Blomberg
Germany
Tel. +49 5235 300
Fax +49 5235 3 41200
<http://www.phoenixcontact.com>